

VIBRO/DYNAMICS

vibration and shock isolation systems

Micro/Level® Isolators



MXL

MXLP

Vibro/Dynamics MXL & MXLP Series Micro/Level Isolators are designed for the free-standing installation of large Mechanical Presses, weighing from 113,500 to over 2.3 million kg. (250,000 to 5 million lbs.)

This innovative *patented* design combines multiple layer elastomer technology with our popular Hydra/Level® hydraulic lift-assist feature.

By using multiple layers of elastomers, isolator dynamic natural frequencies can be as low as 8 Hz. This results in very effective vibration and shock isolation.

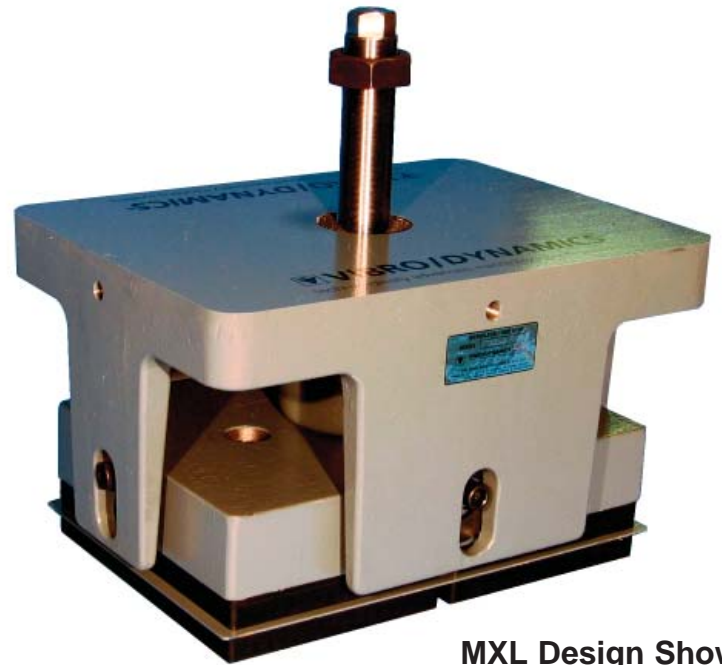

MXL Design Shown

- Faster, easier installations
- Highly effective vibration and shock control
- Precision leveling and alignment
- Proper machine support
- Built-in or portable Hydra/Level® capability

VIBRO/DYNAMICS

Micro/Level® Isolators



The Hydra/Level® System is a patented hydraulic lift-assist system available in MXL and HXL Micro/Level Isolators. Portable or built-in hydraulic cylinders make leveling and aligning even the heaviest machines faster and easier, especially when aligning a transfer press with rolling bolster rails.

No separate jacks or cribbing are necessary. Installation times are typically reduced by several days. In an actual Hydra/Level installation, a machine weighing 4,500,000 lb. was leveled and aligned in less than half a day.

When the internal hydraulics are activated, the load on the precision leveling screw is reduced until it can be adjusted by hand. Precision leveling adjustments are made in this manner. The process is repeated until the press is perfectly level and aligned and the support is Fine-Tuned.

Technical Assistance

To assure the best installation, our application engineers will carefully analyze your particular application needs and recommend the proper isolator for the best installation. Please give us a call, and we will be happy to assist you in your selection.

LIT-MXL 2011.06

The MXL & MXLP Designs

MXL and MXLP Isolators offer Hydra/Level® lift-assist Technology in two ways.

MXL and MXLP Isolators are Hydra/Level capable. Hydraulic cylinders are temporarily installed during leveling and alignment, then removed. The cylinders can then be used for another machine.

HXL and HXLP isolators have hydraulic cylinders permanently built-in.

The advantage is convenience during and after the initial installation.

Permanently mounted cylinders provide faster installations and, if your foundation should settle, provide easy releveling and alignment to get you back in production faster.

Vibro/Dynamics also offers a Hydra/Level service that includes cylinders, pumps, and supervisory assistance.

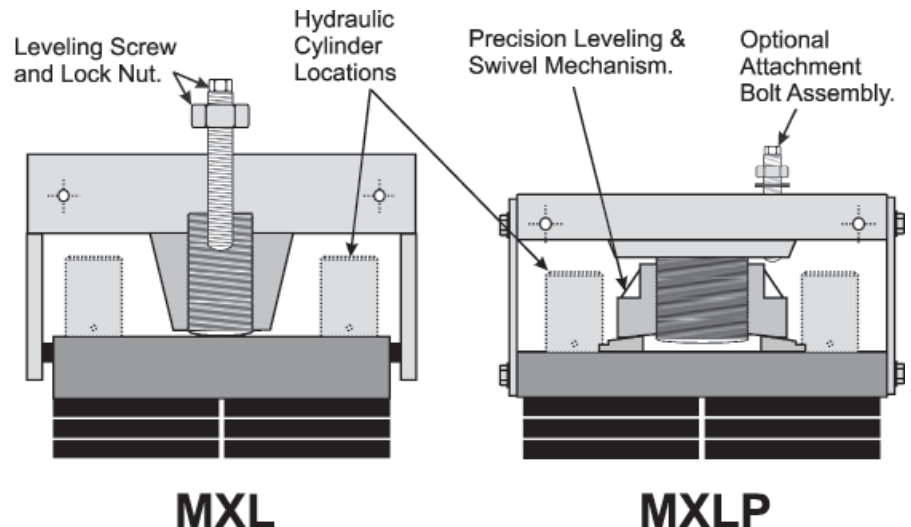

VIBRO/DYNAMICS Corporation

2443 Braga Drive
Broadview, IL 60155-3941
E-Mail: vibro@vibrodynamics.com
Web site: www.vibrodynamics.com

Telephone 708-345-2050
Toll-Free in USA 1-800-842-7668
Fax 708-345-2225

Vibro/Dynamics, Micro/Level, and Hydra/Level are registered trademarks of Vibro/Dynamics Corporation.
©1999-2011 Vibro/Dynamics Corporation.
Vibro/Dynamics Products are covered by one or more U.S. and Foreign Patents.